

M/A-COM AlGaAs Beam Lead PIN Diode

V 1.00

MA4AGBLP912

Features

- Ultra Low Capacitance < 22 fF
- Excellent RC Product < 0.10 pS
- High Switching Cutoff Frequency > 110 GHz
- 5 Nanosecond Switching Speed
- Driven by Standard +5 V TTL PIN Diode Driver
- Silicon Nitride Passivation
- Polyamide Scratch Protection

Description

M/A-COM's MA4AGBLP912 is an Aluminum-Gallium-Arsenide Anode Enhanced, Beam Lead PIN Diode. AlGaAs anodes, which utilize M/A-COM's patent pending hetero-junction technology, produce less diode "On" resistance than conventional GaAs devices. These devices are fabricated on a OMCVD epitaxial wafer using a process designed for high device uniformity and extremely low parasitics. The diodes themselves exhibit low series resistance (4 Ω), low capacitance (20 fF), and extremely fast switching speed, (5 nS). They are fully passivated with silicon nitride and have an additional layer of a polymer for scratch protection. The protective coating prevents damage to the junction and the anode air bridges during handling.

Applications

The ultra low capacitance of the MA4AGBLP912 device allows use through W-band (110 GHz) applications. The low RC product and low profile of the PIN diodes makes it ideal for use in microwave and millimeter wave switch designs, where lower insertion loss and higher isolation are required. The + 10 mA (low loss state) and the 0v (isolation state) bias of the diodes allows the use a simple + 5 V TTL gate driver. These AlGaAs diodes are used as switching arrays on radar systems, high-speed ECM circuits, optical switching networks, instrumentation, and other wideband multi-throw switch assemblies.

Outline (Topview)

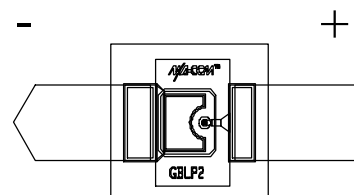

Absolute Maximum Ratings

@ +25 °C¹

| Parameter | Maximum Rating |
|------------------------------------|---------------------|
| Operating Temperature | -65 °C to +125 °C |
| Storage Temperature | -65 °C to +150 °C |
| Mounting Temperature | +235 °C for 10 sec. |
| C.W. Incident RF Power | + 23 dBm C. W. |
| Forward D.C. Current | 40 mA |
| Reverse D.C. Voltage @ -10 μ A | -50 V |

1. Exceeding any of these values may result in permanent damage

Electrical Specifications @ $T_A = 25\text{ }^\circ\text{C}$

| Parameters and Test Conditions | Symbol and Unit | | Units | | |
|---|-----------------|-------|-------|------|------|
| | | | Min. | Typ. | Max. |
| Total Capacitance at -5 V at 10 GHz ¹ | Ct | fF | - | 20 | 22 |
| Forward Resistance at +20 mA at 10 GHz ² | Rs | Ohms | - | 4.0 | 4.9 |
| Forward Voltage at +10 mA | Vf | Volts | - | 1.36 | 1.50 |
| Leakage Current at -40 V | Ir | nA | - | -50 | -300 |
| Minority Carrier Lifetime | TL | nS | - | 5 | 10 |

NOTES:

1. Reverse Bias Capacitance is measured as a Single Series diode at -5 V in a 50 Ω test fixture at 10 GHz.
2. Forward Series Resistance is measured as a Single Series diode at 20 mA in a 50 Ω test fixture at 10 GHz.

Assembly Considerations

The following precautions should be observed to avoid damaging these chips.

Cleanliness

These devices should be handled in a clean environment. Do not attempt to clean die after installation.

Static Sensitivity

Aluminum Gallium Arsenide PIN diodes are Class 1 ESD sensitive and can be damaged by static electricity. Proper ESD techniques should be used when handling these devices.

General Handling

These devices have a polymer layer which provides scratch protection for the junction area and the anode air bridge. Beam lead devices must, however, be handled with extreme care since the leads may easily be distorted or broken by the normal pressures exerted when handled with tweezers. A vacuum pencil with a #27 tip is recommended for picking and placing.

These devices were designed to be inserted onto hard or soft substrates. Recommended methods of attachment include thermocompression bonding, parallel-gap welding, solder reflow, and electrically conductive silver epoxy.

See Application Note M541, "Bonding and Handling Procedures for Chip Diode Devices" for More Detailed Assembly Instructions.

Diode Model

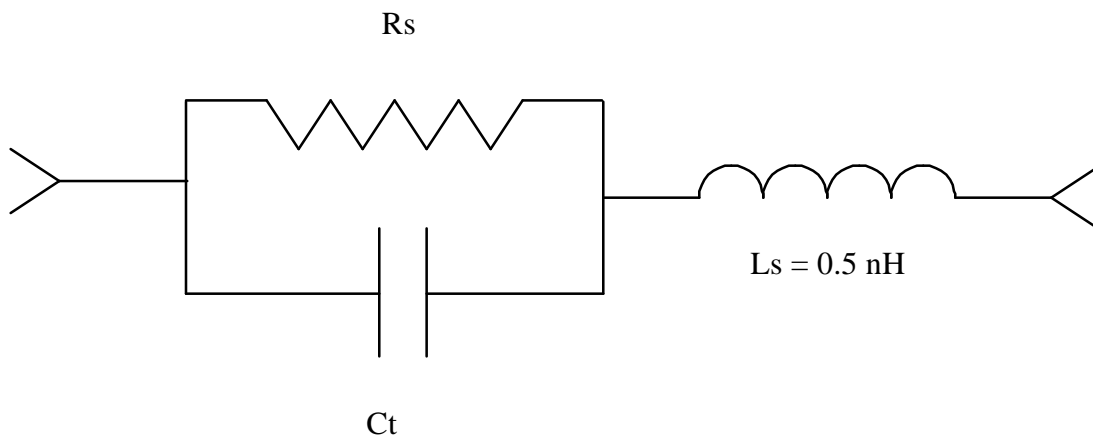

Outline Dimensions — Topview and Sideview

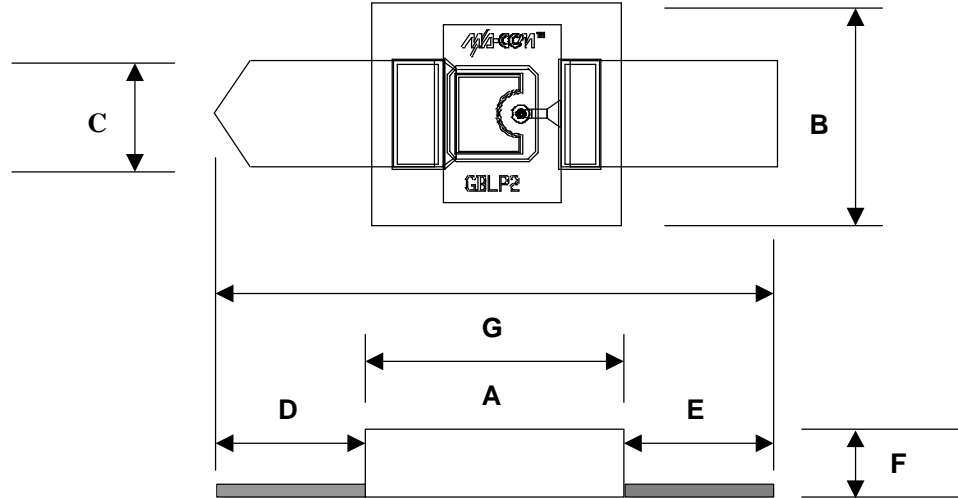

| Dim | Mils | mm |
|-----|--------------|----------------|
| A | 11.0 +/- 2.0 | 0.28 +/- 0.05 |
| B | 6.9 +/- 2.0 | 0.18 +/- 0.05 |
| C | 4.7 +/- 1.0 | 0.12 +/- 0.025 |
| D | 6.9 +/- 2.0 | 0.18 +/- 0.05 |
| E | 6.9 +/- 2.0 | 0.18 +/- 0.05 |
| F | 4.0 +/- 2.0 | 0.10 +/- 0.05 |
| G | 24.8 +/- 3.0 | 0.63 +/- 0.75 |

Diode SPICE Values

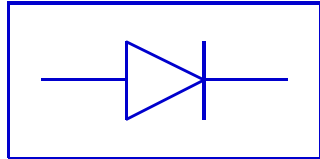

MA4AGBPL912 SPICE Model

PinDiodeModel

$$I_s = 1.0E-14 \text{ A}$$

$$V_i = 0.0 \text{ V}$$

$$wBv = 50 \text{ V}$$

$$\mu_e = 8600 \text{ cm}^2/\text{V}\cdot\text{sec}$$

$$wPmax = 100 \text{ mW}$$

$$W_i = 3.0 \text{ um}$$

$$Ffe = 1.0$$

$$R_r = 10 \text{ K Ohms}$$

$$C_{jmin} = 0.020 \text{ pF}$$

$$\tau = 10 \text{ nsec}$$

$$R_s(I) = R_c + R_j(I) = 0.10 \text{ Ohm} + R_j(I)$$

$$C_{j0} = 0.022 \text{ pF}$$

$$V_j = 1.35 \text{ V}$$

$$M = 0.5$$

$$F_c = 0.5$$

$$I_{max} = 0.04 \text{ A}$$

$$K_f = 0.0$$

$$A_f = 1.0$$